

**SFP+ Bi-Directional 10G 10Km**  
**1270/1330nmTx / 1330/1270nmRx**



**Overview**

The SFPP-10GWxxx-D10 series single mode transceiver is small form factor pluggable module for duplex optical data communications such as 10G-LR/LW defined by IEEE 802.3ae. It is with the SFP+ 20-pin connector to allow hot plug capability.

The SFPP-10GWxxx-D10 module is designed for single mode fiber and operates at a nominal wavelength of 1270nm or 1330nm. The transmitter section uses a multiple quantum well DFB, which is class 1 laser compliant according to International Safety Standard IEC-60825.

The receiver section uses an integrated InGaAs detector preamplifier (IDP) mounted in an optical header and a limiting post-amplifier IC.

**Features**

- ◆ Supports 9.95Gb/s to 10.3Gb/s data rates
- ◆ Simplex LC Connector BIDI SFP+ Optical Transceiver
- ◆ Single 3.3V Supply
- ◆ Up to 10km on 9/125um SMF
- ◆ A:1270nm DFB Laser transmitter,1330nm receiver
- ◆ B:1330nm DFB Laser transmitter,1270nm receiver
- ◆ Compliant with IEEE 802.3ae 10G-LR and 10G-LW
- ◆ SFP+ MSA SFF-8431 Compliant
- ◆ Digital Diagnostic SFF-8472 Compliant
- ◆ RoHS compliant and Lead Free 
- ◆ Operating case temperature:  
Standard: 0 ~ 70 °C

**Applications**

- ◆ 10GBASE-LR at 10.3125Gbps
- ◆ 10GBASE-LW at 9.953Gbps
- ◆ Other Optical Links

**Ordering information**

Part Number	Product Description
SFPP-10GWA73-D10	SFP+ BIDI 10Gbps, 1270nm/1330nm, 10km, 0°C ~ +70°C
SFPP-10GWB37-D10	SFP+ BIDI 10Gbps, 1330nm/1270nm, 10km, 0°C ~ +70°C

### Absolute Maximum Ratings

These values represent the damage threshold of the module. Stress in excess of any of the individual Absolute Maximum Ratings can cause immediate catastrophic damage to the module even if all other parameters are within Recommended Operating Conditions.

Parameters	Symbol	Min.	Max.	Unit
Supply Voltage	$V_{CC}$	-0.5	+3.6	V
Storage Temperature	$T_C$	-40	+85	°C
Operating Case Temperature	$T_C$	0	+70	°C
Relative Humidity	RH	0	85	%

### Recommended Operating Conditions

Parameter	Symbol	Min.	Typical	Max	Unit
Supply Voltage	$V_{CC}$	3.0	3.3	3.6	V
Supply Current	$I_{CC}$		300	420	mA
Operating Case Temperature	$T_C$	0	25	70	°C
Module Power Dissipation	$P_m$	-	1	1.5	W

**Notes:**

- [1] Supply current is shared between VCCTX and VCCR<sub>X</sub>.  
 [2] In-rush is defined as current level above steady state current requirements.

### Electrical characteristics ( $T_{OP} = 0$ to $70^{\circ}C$ , $V_{CC} = 3.0$ to $3.60$ Volts)

Parameter	Symbol	Min.	Typical	Max	Unit	Ref.
Supply Voltage	$V_{CC}$	3.00		3.60	V	1
Supply Current	$I_{CC}$			420	mA	1
<b>Transmitter</b>						
Input differential impedance	$R_{in}$		100		$\Omega$	2
Single ended data input swing	$V_{in,pp}$	150		1200	mVpp	
Transmit Disable Voltage	$V_D$	2		$V_{CC}$	V	
Transmit Enable Voltage	$V_{EN}$	Vee		Vee+0.8	V	3
<b>Receiver</b>						
Output differential impedance	$R_{out}$		100		$\Omega$	2
Single ended data output swing	$V_{out,pp}$	300		700	mV	4
LOS Fault	$V_{LOS\ fault}$	2		$V_{CC\_HOST}$	V	5
LOS Normal	$V_{LOS\ norm}$	Vee		Vee+0.8	V	5

**Notes:**

1. Module power consumption never exceeds 1W.
2. AC coupled.
3. Or open circuit.

4. Into 100 ohm differential termination.

5. LOS is LVTTTL. Logic 0 indicates normal operation; logic 1 indicates no signal detected.

**Optical characteristics ( $T_{OP} = 0$  to  $70^{\circ}C$ ,  $V_{CC} = 3.0$  to  $3.60$  Volts)**

**(SFPP-10GWA73-D10, 1270 DFB & PIN/TIA)**

Parameter	Symbol	Min.	Typical	Max	Unit	Ref.
<b>Transmitter</b>						
Optical Wavelength	$\lambda_c$	1260	1270	1280	nm	
Side Mode Suppress Ratio	SMSR	30			dB	
Spectral Width(-20dB)	$\Delta\lambda$			1	nm	
Average Output Power	$P_{op}$	-8.2		0.5	dBm	1
Extinction Ratio	ER	3.5			dB	
Eye Mask		Compliant with IEEE 802.3				
Transmitter and Dispersion Penalty	TDP			3.2	dB	
Average Power of OFF Transmitter				-30	dBm	
Relative Intensity Noise	RIN			-128	dB/Hz	
<b>Receiver</b>						
Average Receiver Power	RSENS			-14.1	dBm	1,2
Receiver Overload	$P_{MAX}$			+0.5	dBm	
Centre Wavelength	$\lambda_C$	1320		1340	nm	
LOS De-Assert	$LOS_D$			-15	dBm	
LOS Assert	$LOS_A$	-30			dBm	
LOS Hysteresis		0.5			dB	

**Notes:**

1. Average Receiver Power (Min) is informative and not the principal indicator of signal strength. A received power below this value cannot be compliant.
2. Measured with a PRBS<sup>231</sup>-1 test pattern @10.3125Gbps, BER $\leq$ 10<sup>-12</sup>

**(SFPP-10GWB37-D10, 1330 DFB & PIN/TIA)**

Parameter	Symbol	Min.	Typical	Max	Unit	Ref.
<b>Transmitter</b>						
Optical Wavelength	$\lambda_c$	1320	1330	1340	nm	
Side Mode Suppress Ratio	SMSR	30			dB	
Spectral Width(-20dB)	$\Delta\lambda$			1	nm	
Average Output Power	$P_{op}$	-8.2		0.5	dBm	1,2
Extinction Ratio	ER	3.5			dB	

Eye Mask		Compliant with IEEE 802.3				
Transmitter and Dispersion Penalty	TDP			3.2	dB	
Average Power of OFF Transmitter				-30	dBm	
Relative Intensity Noise	RIN			-128	dB/Hz	
Receiver						
Average Receiver Power	RSENS			-14.1	dBm	2,3
Receiver Overload	P <sub>MAX</sub>			+0.5	dBm	
Centre Wavelength	$\lambda_c$	1260		1270	nm	
LOS De-Assert	LOS <sub>D</sub>			-15	dBm	
LOS Assert	LOS <sub>A</sub>	-30			dBm	
LOS Hysteresis		0.5			dB	

**Notes:**

1. Output is coupled into a 9/125um SMF.
2. Average Receiver Power (Min) is informative and not the principal indicator of signal strength. A received power below this value cannot be compliant.
3. Measured with a PRBS231-1 test pattern @10.3125Gbps, BER≤10<sup>-12</sup>

**Pin Descriptions**

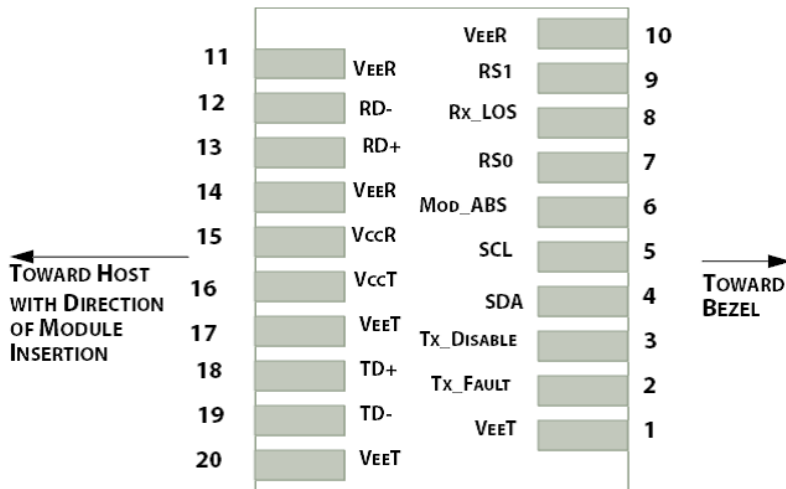

Figure2. Electrical Pin-out Details

Pin	Symbol	Name/Description
1	VEET [1]	Transmitter Ground
2	Tx_FAULT [2]	Transmitter Fault
3	Tx_DIS [3]	Transmitter Disable. Laser output disabled on high or open

4	SDA [2]	2-wire Serial Interface Data Line
5	SCL [2]	2-wire Serial Interface Clock Line
6	MOD_ABS [4]	Module Absent. Grounded within the module
7	RS0 [5]	RS0 for Rate Select: Open or Low = Module supports ≤4.25Gbps High = Module supports 9.95 Gb/s to 10.3125 Gb/s
8	RX_LOS [2]	Loss of Signal indication. Logic 0 indicates normal operation
9	RS1 [5]	No connection required
10	VEER [1]	Receiver Ground
11	VEER [1]	Receiver Ground
12	RD-	Receiver Inverted DATA out. AC Coupled
13	RD+	Receiver DATA out. AC Coupled
14	VEER [1]	Receiver Ground
15	VCCR	Receiver Power Supply
16	VCCT	Transmitter Power Supply
17	VEET [1]	Transmitter Ground
18	TD+	Transmitter DATA in. AC Coupled
19	TD-	Transmitter Inverted DATA in. AC Coupled
20	VEET [1]	Transmitter Ground

**Notes:**

- [1]. Module circuit ground is isolated from module chassis ground within the module.
- [2]. Should be pulled up with 4.7k – 10k ohms on host board to a voltage between 3.15V and 3.6V.
- [3]. Tx\_Disable is an input contact with a 4.7 kΩ to 10 kΩ pullup to VccT inside the module.
- [4]. Mod\_ABS is connected to VeeT or VeeR in the SFP+ module. The host may pull this contact up to Vcc\_Host with a resistor in the range 4.7 kΩ to 10 kΩ. Mod\_ABS is asserted “High” when the SFP+ module is physically absent from a host slot.
- [5]. RS0 and RS1 are module inputs and are pulled low to VeeT with > 30 kΩ resistors in the module.

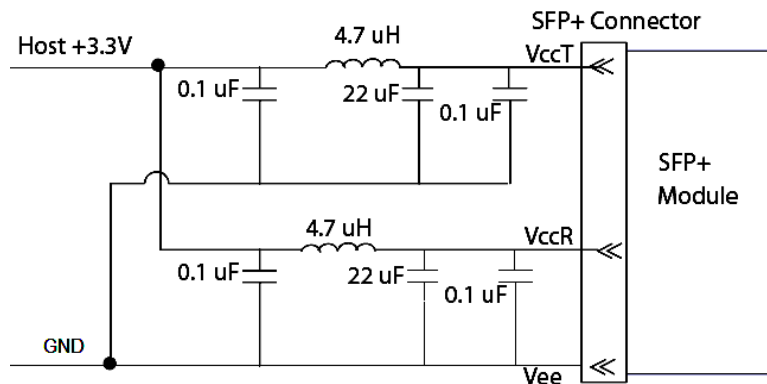

Figure2. Host Board Power Supply Filters Circuit

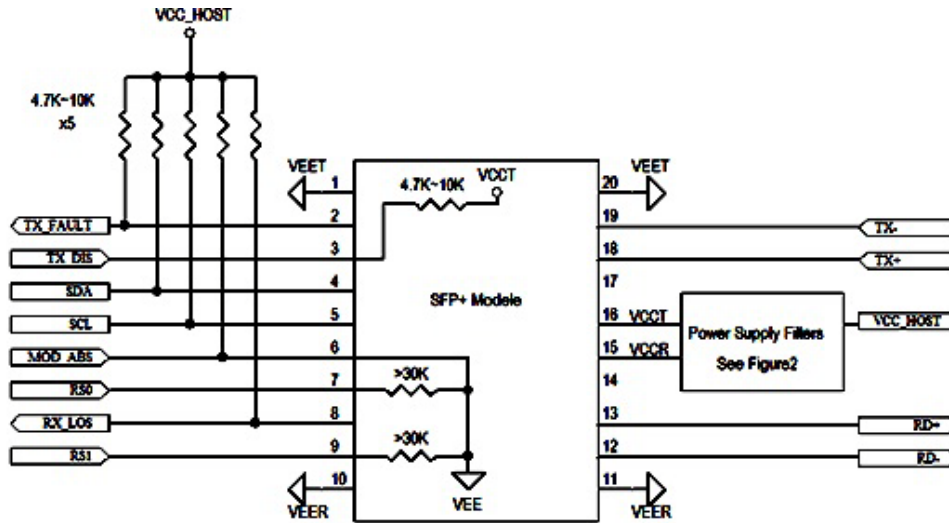

Figure3. Host-Module Interface

## Mechanical Dimension

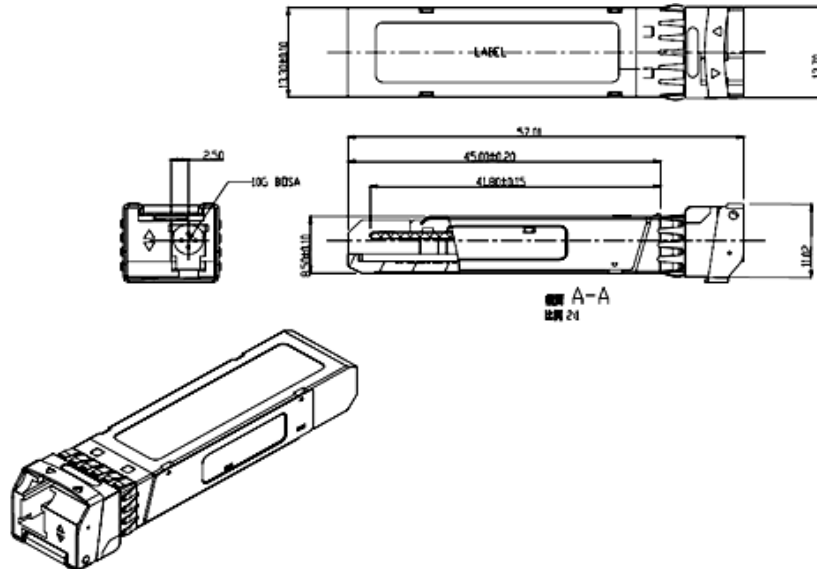

Figure4. Key Mechanical Specifications