

SFP+ 10G 1310nm 220M LRM



Overview

APC's SFP+ LRM is an optical transceiver module for transmission at 1310nm over legacy multi-mode fiber. Supporting 10GBASE-LRM Ethernet standard make it ideally suited for 10G datacom. It's very low power consumption and its excellent EMI performance allows system design with high port density. The small form factor integrates a 1310nm Fabry-Perot (FP) laser in an LC package and a linear multimode PIN receiver. Sourcelight module is lead free, RoHS compliant and is designed and tested in accordance with industry safety standards.

Features

- ◆ Supports 9.95 to 10.3Gbps bit rates
- ◆ Transmission distance up to 220m (OM1 fiber)
- ◆ Hot Pluggable SFP+ footprint
- ◆ 1310nm FP transmitter, PIN photo-detector
- ◆ Digital Status monitoring Interface
- ◆ Duplex LC connector
- ◆ RoHS compliant and Lead Free 
- ◆ Metal enclosure for lower EMI
- ◆ Single 3.3V power supply
- ◆ Power dissipation < 1W
- ◆ Operating case temperature: 0 to 70 °C
- ◆ Compliant with FC-P1-4 800-Mx-SN-I, SFF-8431 , SFF-8432 and SFF-8472

Applications

- ◆ 10GBASE-LRM 10G Ethernet
- ◆ Legacy FDDI multimode links

Ordering information

Part Number	Product Description
SFPP-10GFX13-DX2	SFP+ 10Gpbs, 1310nm, MMF, 220m, 0°C ~ +70°C

Product description

The APC SFP-10GFX13-DX2 SFP+ transceiver is a linear-interface transceiver that enables, in conjunction with an Electronic Dispersion Compensation (EDC) on the host board, an IEEE802.3aq 10GBASE-LRM compliant link. The host board EDC provides correction for the severe modal dispersion that may occur during propagation through multimode fiber links, including legacy installed FDDI multimode fiber (see IEEE802.3aq for detailed information regarding fiber coverage).

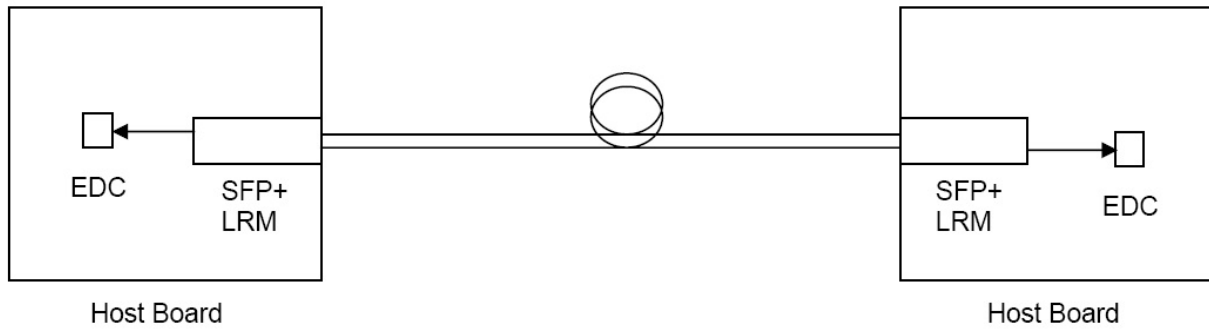

Figure1. Block Diagram of SFP+ LRM Module on Host Board with EDC

Unlike the XFP MSA transceiver requirements, the SFP+ transceiver does not contain internal retiming circuitry, and thus some of the Transmitter Optical Characteristics stated in this data sheet require that the Host Board is compliant to the SFP+ MSA specifications. See Chapter 3 in Reference [1] for further details.

Absolute maximum rating

These values represent the damage threshold of the module. Stress in excess of any of the individual Absolute Maximum Ratings can cause immediate catastrophic damage to the module even if all other parameters are within Recommended Operating Conditions.

Parameters	Symbol	Min.	Max.	Unit
Power Supply Voltage	V_{CC}	0	+3.6	V
Storage Temperature	T_c	-40	+85	°C
Operating Case Temperature	T_c	0	+70	°C
Relative Humidity	RH	5	95	%

Recommended operating environment

Recommended Operating Environment specifies parameters for which the electrical and optical characteristics hold unless otherwise noted.

Parameter	Symbol	Min.	Typical	Max	Unit
Power Supply Voltage	V_{CC}	3.135	3.300	3.465	V
Operating Case Temperature	T_c	0	25	70	°C

LOW Speed Characteristics

Parameter	Symbol	Min.	Typical	Max	Unit
Power Consumption			0.8	1	W
TX_Fault,RX_LOS	VOL	0		0.4	V
	VOH	Host_Vcc-0.5		Host_Vcc+0.3	V
TX_DIS	VIL	-0.3		0.8	V
	VIH	2.0		VCCT+0.3	V
RS0,RS1	VIL	-0.3		0.8	V
	VIH	2.0		VCCT+0.3	V

Electrical characteristics

Parameter	Conditions	Symbol	Min.	Typical	Max	Unit
Nominal Data Rate		VID		10.3125		Gbps
Supply Voltage		Vcc	3.14		3.46	V
Supply Current		Icc		200	300	mA
Power Dissipation		P			1	W
Transmitter						
Input differential impedance	2	Rin		100		Ω
Single ended data input swing	3	Vin,pp	90		350	mV
Transmit Disable Voltage	4	VD	2		Vcc	V
Transmit Enable Voltage		VEN	Vee		Vee+0.8	V
Receiver						
Termination Mismatch at 1 MHz		ΔZM			5	%
Single Ended Output Voltage Tolerance			-0.3		4.0	V
Output AC Common Mode Voltage					7.5	mV RMS
Output Rise and Fall time (20% to 80%)	5	Tr, Tf	30			Ps
Relative Noise LRM Links with crosstalk	6	dRNx			TBD equation	dB/Hz
Difference Waveform Distortion Penalty	7	dWDP	per SFF-8431			dB
Differential Voltage Modulation Amplitude		VMA	180		600	mV
LOS Fault	8	VLOS fault	2		VccHOST	V
LOS Normal	8	VLOS norm	Vee		Vee+0.8	V
Power Supply Noise Tolerance	9	VccT/VccR	per SFF-8431			mVpp

Notes:

1. Non-condensing.
2. Connected directly to TX data input pins. AC coupling from pins into laser driver IC.
3. Per SFF-8431 Rev 3.0
4. Into 100 ohms differential termination.

5. Measured with Module Compliance Test Board and OMA test pattern.
6. Crosstalk source rise/fall time (20%-80%) is 35 ps.
7. Defined with reference receiver with 14 T/2 spaced FFE taps and 5 T spaced DFE taps.
8. LOS is an open collector output. Should be pulled up with 4.7k – 10kΩ on the host board. Normal operation is logic 0; loss of signal is logic 1. Maximum pull-up voltage is 5.5V.
9. As described in Section 2.8.1, SFF-8431 Rev 3.0.

General Specifications

Parameter	Symbol	Min.	Typical	Max	Unit	Notes
Bit Rate	BR		10.3125		Gb/sec	1
Bit Error Ratio	BER			10 ⁻¹²		2
Maximum Supported Distances						
Fiber Type	1310nm OFL Bandwidth					
62.5μm	“FDDI” 160MHz/km	Lmax		220	m	3
	OM1 200MHz/km			220		
50μm	400MHz/km	Lmax		100	m	3
	OM2 500MHz/km			220		
	OM3 2000MHz/km			220		

Notes:

1. 10GBASE-LRM
2. Tested with a 231 – 1 PRBS
3. Operating range as defined by IEEE standards. Longer reach possible depending upon link implementation.

Optical characteristics

Parameter	Symbol	Min.	Typical	Max	Unit	Notes
Transmitter						
Center Wavelength	λ_t	1260		1355	nm	
RMS spectral width	λ_{rms} @1260nm			2.4	nm	2
	λ_{rms} @ 1260nm-1300	-	-	2.4		
	λ_{rms} @ 1300nm-1355			4		
Average Optical Power	Pavg	-6.5	-	0.5	dBm	1
Extinction Ratio	ER	3.5	-	-	dB	
Optical Modulation Amplitude (OMA)	POMA	-4.5		+1.5	dBm	
Peak Launch Power	PMAX			3	dBm	
Transmitter Waveform Dispersion Penalty	TWDP			4.7	dB	3

Average Launch power of OFF transmitter	POFF			-30	dBm	
Uncorrelated Jitter [rms]	T _{xj}			0.033	UI	
Encircled Flux	<5 μ m	30			%	
	<11 μ m	81				
Transmitter Reflectance				-12	dB	
Optical Return Loss Tolerance		20			dB	
Relative Intensity Noise	R _{in}			-128	dB/Hz	
Receiver						
Comprehensive Stressed Receiver Sensitivity (OMA) @ 10.3125Gb/s	Precursor	-	-	-6.5	dBm	5
	Symmetrical			-6	dBm	
	Postcursor			-6.5	dBm	
LOS Assert	LosA	-30	-		dBm	
LOS De-assert	LosD			-11	dBm	
Overload	P _{MAX}	+1.5	-		dBm	4
Receiver Reflectance		-	-	-12	dB	
LOS Hysteresis		0.5			dB	

Notes:

1. Average power figures are informative only, per IEEE802.3aq
2. Maximum RMS spectral width as specified by Figure 3
3. Optical Eye Mask requires the host board to be SFF-8431 compliant. Optical eye mask per IEEE802.3aq.
4. TWDP figure requires the host board to be SFF-8431 compliant. TWDP is calculated using the Matlab code provided in clause 68.6.6.2 of IEEE802.3aq
5. Receiver overload specified in OMA and under the worst comprehensive stressed condition.
6. Conditions of stressed receiver tests per IEEE802.3aq. CSRS testing requires the host board to be SFF-8431 compliant.

Digital Diagnostic Functions

The following digital diagnostic characteristics are defined over the Recommended Operating Environment unless otherwise specified. It is compliant to SFF8472 Rev9.2 with internal calibration mode. For external calibration mode please contact our sales staff.

Parameter	Symbol	Min.	Max	Unit	Notes
Accuracy					
Transceiver Temperature	DMI_Temp	-3	+3	degC	Over operating temp
TX Output optical power	DMI_TX	-3	+3	dBm	
RX Input optical power	DMI_RX	-3	+3	dBm	-3dBm to -12dBm range
Transceiver Supply voltage	DMI_VCC	-0.08	+0.08	V	Full operating range
Bias current monitor	DMI_Ibias	-10%	10%	mA	
Dynamic Range Accuracy					
Transceiver Temperature	DMI_Temp	-5	70	degC	

TX Output optical power	DMI_TX	-9	-1	dBm	
RX Input optical power	DMI_RX	-18	0	dBm	
Transceiver Supply voltage	DMI_VCC	3.0	3.6	V	
Bias current monitor	DMI_Ibias	0	70	mA	

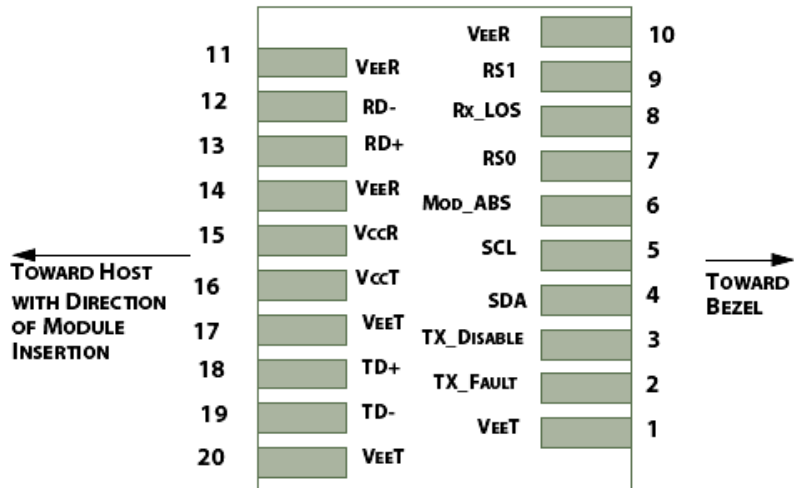

Figure 2: Interface to Host PCB

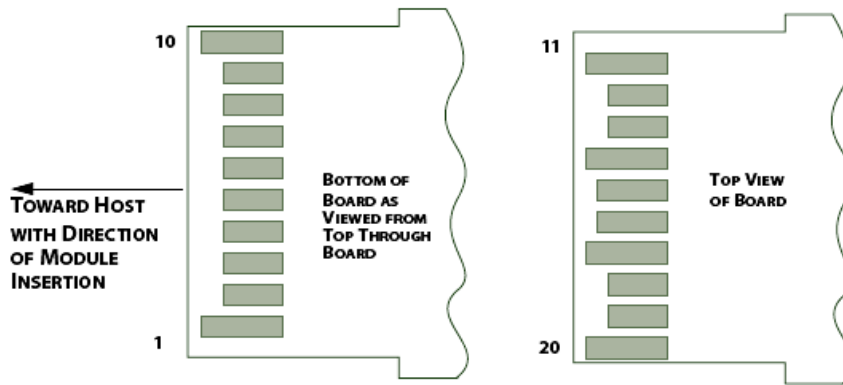

Figure 3: Module Contact Assignment

Pin definition

Pin	Symbol	Name/Description
1	VEET [1]	Transmitter Ground
2	Tx_FAULT [2]	Transmitter Fault
3	Tx_DIS [3]	Transmitter Disable. Laser output disabled on high or open
4	SDA [2]	2-wire Serial Interface Data Line

5	SCL [2]	2-wire Serial Interface Clock Line
6	MOD_ABS [4]	Module Absent. Grounded within the module
7	RS0 [5]	Rate Select 0
8	RX_LOS [2]	Loss of Signal indication. Logic 0 indicates normal operation
9	RS1 [5]	Rate Select 1
10	VEER [1]	Receiver Ground
11	VEER [1]	Receiver Ground
12	RD-	Receiver Inverted DATA out. AC Coupled
13	RD+	Receiver DATA out. AC Coupled
14	VEER [1]	Receiver Ground
15	VCCR	Receiver Power Supply
16	VCCT	Transmitter Power Supply
17	VEET [1]	Transmitter Ground
18	TD+	Transmitter DATA in. AC Coupled
19	TD-	Transmitter Inverted DATA in. AC Coupled
20	VEET [1]	Transmitter Ground

Notes:

- [1]. Module circuit ground is isolated from module chassis ground within the module.
- [2]. Should be pulled up with 4.7k – 10k ohms on host board to a voltage between 3.15V and 3.6V.
- [3]. Tx_Disable is an input contact with a 4.7 kΩ to 10 kΩ pullup to VccT inside the module.
- [4]. Mod_ABS is connected to VeeT or VeeR in the SFP+ module. The host may pull this contact up to Vcc_Host with a resistor in the range 4.7 kΩ to 10 kΩ. Mod_ABS is asserted “High” when the SFP+ module is physically absent from a host slot.
- [5]. RS0 and RS1 are module inputs and are pulled low to VeeT with > 30 kΩ resistors in the module.

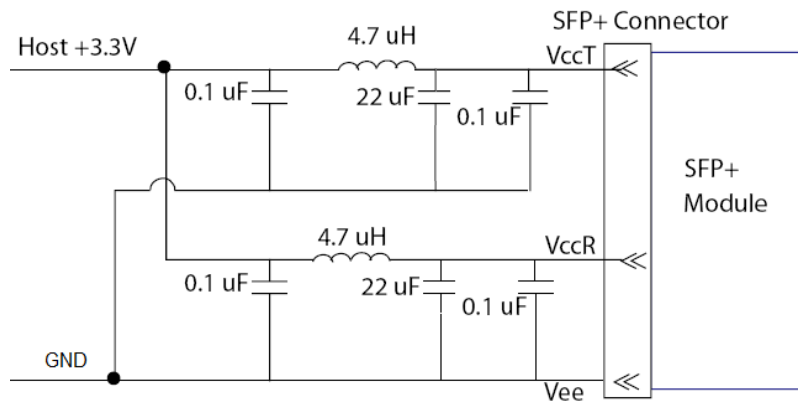

Figure4. Host Board Power Supply Filters Circuit

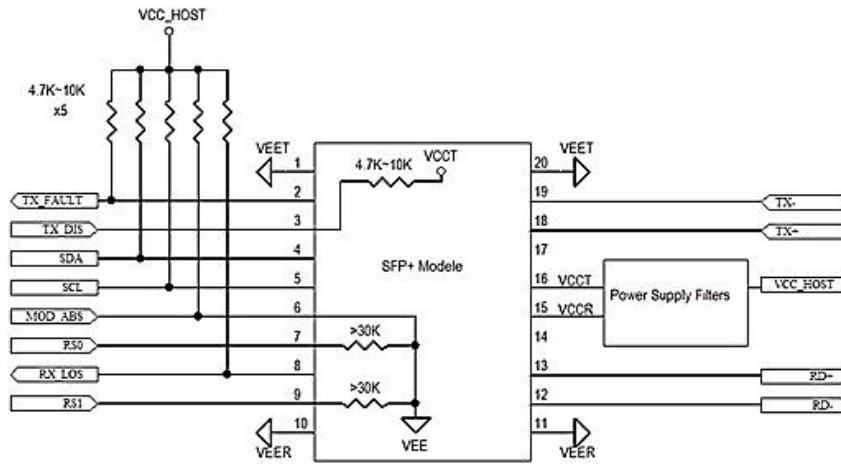

Figure5. Host-Module Interface

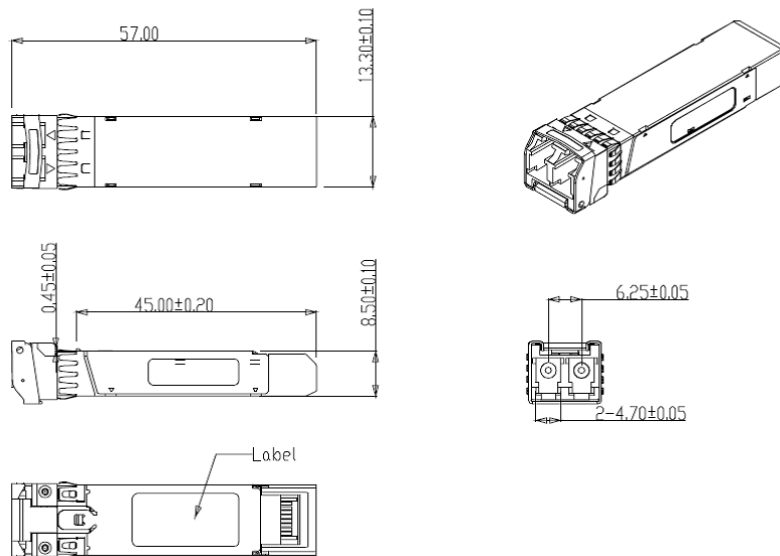

Figure6. Mechanical Specifications

References

1. "Specifications for Enhanced Small Form Factor Pluggable Module SFP+", SFF-8431, Rev 4.1, July 6, 2009.
2. "Improved Pluggable Formfactor", SFF-8432, Rev 4.2, Apr 18, 2007
3. IEEE802.3aq
4. "Diagnostic Monitoring Interface for Optical Transceivers" SFF-8472, Rev 10.3, Dec 1, 2007