

Description

General

The SFP-1000FX13-D10D transceiver from APC is small form factor pluggable module with standard LC duplex connector for fiber communications. This module is designed for single mode fiber and operates at a nominal wavelength of 1310 nm with cost effective and high performance. It is with the SFP 20-pin connector to allow hot plug capability.



Transmitter Section

The transmitter consists of a high-performance 1310 nm Fabry-Perot (FP) laser, which is housed within a metal package. In addition, this component is also class 1 laser compliant with according to International Safety Standard IEC-825

Receiver Section

The receiver contain of an InGaAs PIN photodiode coupled to a high sensitivity transimpedance amplifier (TIA) in an OSA. This OSA combination is mated to a post amplifier IC that provides the post amplification and LOS (Loss of Signal) indication circuit, which provides LVTTTL logic high state output when a unusable input optical signal level is detected.

Features

- Single + 3.3 V power Supply
- Small Form Factor Pluggable MSA Compliant.
- Compliant With IEEE 802.3z Gigabit Ethernet Standard
- PECL Differential Inputs and Output
- TTL Signal Detect Indicator.
- For Single Mode Applications
- LC Duplex Connector
- Class 1 Laser International Safety Standard IEC 825 Compliant
- Temperature Ranges: 0°C to +70°C
- Distance Up to 10 km.
- RoHS Compliant

Applications

- Bridges/Routers/intelligent hub and concentrators
- Gigabit Ethernet / Fiber Channel
- Storage Area Network

Performance Specifications

Absolute Maximum Ratings					
Parameter	Symbol	Min	Typ	Max	Unit
Supply Voltage	V _{CC}	0	-	5	V
Storage Temperature	T _S	-40	-	85	°C
Operating Temperature	T _{OP}	0	-	70	°C
Lead Soldering Limits	T _{SOLD}	-	-	260/10	°C/sec
General Specifications					
Parameter	Symbol	Min	Typ	Max	Units
Data Rate	B	-	1.25	-	Gbps
Supported Link Length on 9/125μm SMF	L	-	10	-	Km

Optical and Electrical Characteristics

Transmitter Electrical Characteristics					
Parameter	Symbol	Min	Typ	Max	Unit
Supply Voltage	V_{CC}	3.15	3.3	3.45	V
Supply Current	I_{CC}	-	-	160	mA
Data Differential Input Voltage	$V_{in, pp}$	300	-	1600	mV
Disable Input Voltage	$V_{IL} - V_{CC}$	-1.81	-	-1.48	V
Enable Input Voltage	$V_{IH} - V_{CC}$	-1.16	-	-0.88	V
Transmitter Optical Characteristics					
Parameter	Symbol	Min	Typ	Max	Unit
Output Optical Power	P_O	-9	-	-2	dBm
Center Wavelength	λ_C	1280	1310	1340	nm
Spectral Width (RMS)	$\Delta\lambda$	-	2	-	nm
Optical Rise Time (10%-90%)	t_r	-	-	0.26	ns
Optical Fall Time (10%-90%)	t_f	-	-	0.26	ns
Extinction Ratio	ER	8.2	-	-	dB

Receiver Electrical Characteristics					
Parameter	Symbol	Min	Typ	Max	Unit
Supply Voltage	V_{CC}	3.15	3.3	3.45	V
Supply Current	I_{CC}	-	-	100	mA
Data Differential Output Voltage	$V_{out, pp}$	300	-	1000	mV
Data Output Rise Time (10%-90%)	t_r	-	-	0.35	ns
Data Output Fall Time (10%-90%)	t_f	-	-	0.35	ns
Receiver Optical Characteristics					
Parameter	Symbol	Min	Typ	Max	Unit
Maximum Receiver Power	P_{in}	-3	-	-	dBm
Receiver Sensitivity	P_S	-	-20	-	dBm
Optical Center Wavelength	λ_C	1100	-	1600	nm
Signal Detect-Asserted	P_A	-	-	-20	dBm avg.
Signal Detect-Deasserted	P_D	-36	-	-	dBm avg.
Signal Detect-Hysteresis	$P_A - P_D$	0.5	-	-	dB

Recommended Circuit Schematic

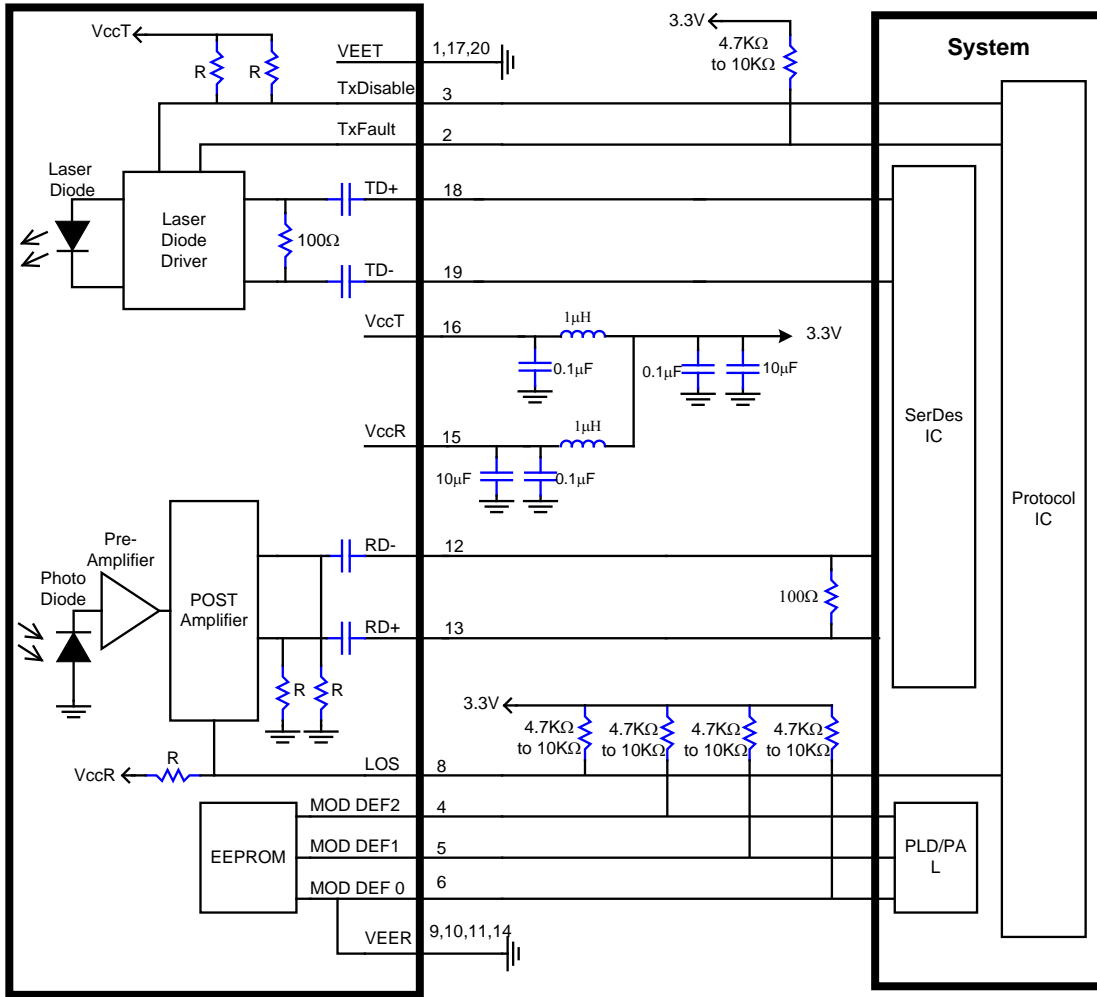

Ordering Information

SFP – 1000FX13 – D10D

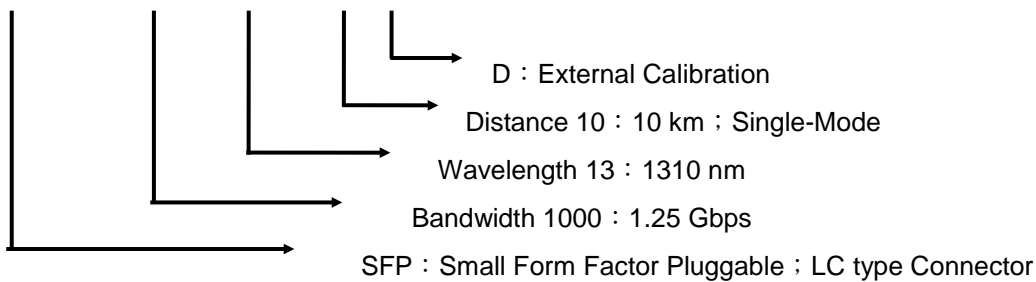

SFP Transceiver Electrical Pad Layout

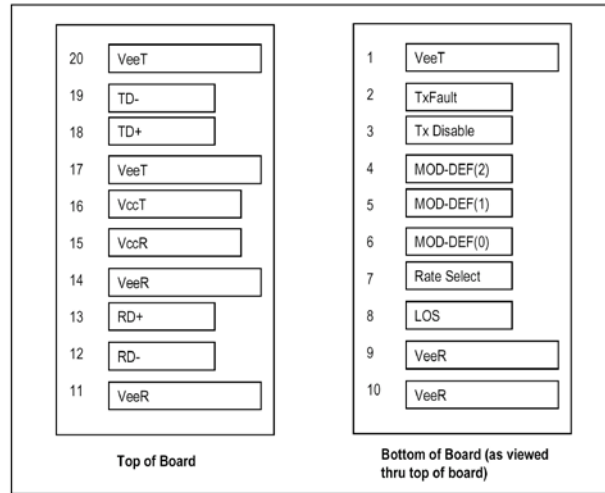

Pinout Table

Pin	Symbol	Name/Description	Ref.
1	V _{EET}	Transmitter Ground	1
2	T _{FAULT}	Transmitter Fault.	4
3	T _{DIS}	Transmitter Disable. Laser output disabled on high or open.	2
4	MOD_DEF (2)	Module Definition 2. Data line for Serial ID.	3
5	MOD_DEF (1)	Module Definition 1. Clock line for Serial ID.	3
6	MOD_DEF (0)	Module Definition 0. Grounded within the module.	3
7	Rate Select	No connection required	
8	LOS	Loss of Signal indication. Logic 0 indicates normal operation.	5
9	V _{EER}	Receiver Ground	1
10	V _{EER}	Receiver Ground	1
11	V _{EER}	Receiver Ground	1
12	RD-	Receiver Inverted DATA out. AC Coupled	
13	RD+	Receiver Non-inverted DATA out. AC Coupled	
14	V _{EER}	Receiver Ground	1
15	V _{CCR}	Receiver Power Supply	
16	V _{CCT}	Transmitter Power Supply	
17	V _{EET}	Transmitter Ground	1
18	TD+	Transmitter Non-Inverted DATA in. 100 ohm termination between TD+ and TD-, AC Coupled thereafter.	
19	TD-	Transmitter Inverted DATA in. See TD+	
20	V _{EET}	Transmitter Ground	1

Notes:

1. Laser output disabled on TDIS >2.0V or open, enabled on TDIS <0.8V.
2. Should be pulled up with 4.7k – 10kohms on host board to a voltage between 2.0V and 5.5V. MOD_DEF (0) pulls line low to indicate module is plugged in.
3. TX-Fault is open collector output. Should be pulled up with 4.7k – 10k ohms on host board to a voltage between 2.0V and 5.5V.
4. LOS is open collector output. Should be pulled up with 4.7k – 10k ohms on host board to a voltage between 2.0V and 5.5V. Logic 0 indicates normal operation; logic 1 indicates loss of signal.

Memory map

The memory map in the following describes an extension to the memory map defined in SFP MSA. The enhanced interface uses the two wire serial bus address 1010001X(A2h) to provide diagnostic information about the module's present operating conditions.

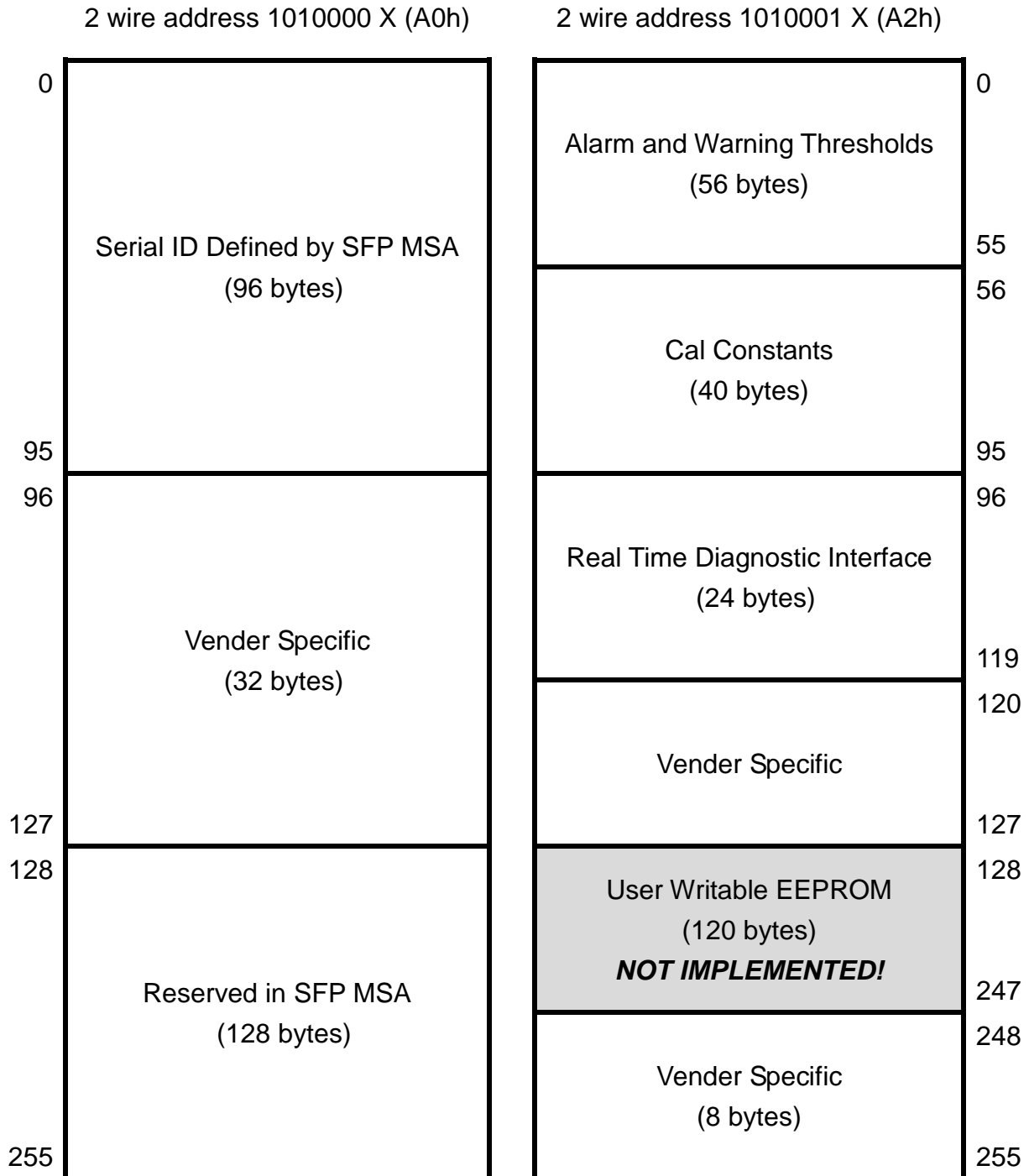

2 Wire Address (A2h, Digital Diagnostic Monitoring Interface)

Alarm and Warning Thresholds

Address	Bytes	Name	HEX	Real Value
00-01	2	Temp High Alarm	5A00	90°C
02-03	2	Temp Low Alarm	0000	0°C
04-05	2	Temp High Warning	5000	80°C
06-07	2	Temp Low Warning	0A00	10°C
08-09	2	Voltage High Alarm	875A	3.465V
10-11	2	Voltage Low Alarm	7A76	3.135V
12-13	2	Voltage High Warning	84D0	3.4V
14-15	2	Voltage Low Warning	7D00	3.2V
16-17	2	Bias High Alarm	618A	50mA
18-19	2	Bias Low Alarm	0000	0mA
20-21	2	Bias High Warning	57E4	45mA
22-23	2	Bias Low Warning	0000	0mA
24-25	2	TX Power High Alarm	3E34	+2dBm
26-27	2	TX Power Low Alarm	03E8	-10dBm
28-29	2	TX Power High Warning	3168	+1dBm
30-31	2	TX Power Low Warning	04EB	-9dBm
32-33	2	RX Power High Alarm	1394	-3dBm
34-35	2	RX Power Low Alarm	0003	-33dBm
36-37	2	RX Power High Warning	0F8D	-4dBm
38-39	2	RX Power Low Warning	0006	-30dBm
40-55	16	Reserved		

Calibration constants (2 Wire Address A2h)

Address	Bytes	Name	Description
56-59	4	Rx_PWR(4)	Rx_PWR(4) is set to zero for "internally calibrated" devices.
60-63	4	Rx_PWR(3)	Rx_PWR(3) is set to zero for "internally calibrated" devices.
64-67	4	Rx_PWR(2)	Rx_PWR(2) is set to zero for "internally calibrated" devices.
68-71	4	Rx_PWR(1)	Rx_PWR(1) is set to 1 for "internally calibrated" devices.
72-75	4	Rx_PWR(0)	Rx_PWR(0) is set to zero for "internally calibrated" devices.
76-77	2	Tx_I(Slope)	Tx_I(Slope) is set to 1 for "internally calibrated" devices.
78-79	2	Tx_I(Offset)	Tx_I(Offset) is set to zero for "internally calibrated" devices.
80-81	2	Tx_PWR(Slope)	Tx_PWR(Slope) is set to 1 for "internally calibrated" devices.
82-83	2	Tx_PWR(Offset)	Tx_PWR(Offset) is set to zero for "internally calibrated" devices.
84-85	2	T (Slope)	T(Slope) is set to 1 for "internally calibrated" devices.
86-87	2	T (Offset)	T(Offset) is set to zero for "internally calibrated" devices.
88-89	2	V (Slope)	V(Slope) is set to 1 for "internally calibrated" devices.
90-91	2	V (Offset)	V(Offset) is set to zero for "internally calibrated" devices.
92-94	3	Reserved	Reserved
95	1	Checksum	Byte 95 contains the low order 8 bits of the sum of bytes 0 – 94.

Digital Monitoring Values (2 Wire Address A2h)

The digital value conversions are updated every 13ms (nominal) or 20ms (max) in rotation. After getting digital value, each measurement could be obtained by multiplying digital value by corresponding LSB value:

Temperature (Signed twos complement value)

A2h Byte 96 (Temperature MSB)								A2h Byte 97 (Temperature LSB)							
S	2 ⁶	2 ⁵	2 ⁴	2 ³	2 ²	2 ¹	2 ⁰	2 ⁻¹	2 ⁻²	2 ⁻³	2 ⁻⁴	2 ⁻⁵	2 ⁻⁶	2 ⁻⁷	2 ⁻⁸

$$\text{Temperature} = \text{Temp (digital monitoring value)} \times \text{LSB}_{\text{Temp}} = \text{Temp (digital monitoring value)} \times \frac{1}{256}$$

V_{cc}, TX Bias, TX Power, RX Power (Unsigned values)

A2h Byte 98 (V _{cc} MSB)								A2h Byte 99 (V _{cc} LSB)							
A2h Byte 100 (TX Bias MSB)								A2h Byte 101 (TX Bias LSB)							
A2h Byte 102 (TX Power MSB)								A2h Byte 103 (TX Power LSB)							
A2h Byte 104 (RX Power MSB)								A2h Byte 105 (RX Power LSB)							
2 ¹⁵	2 ¹⁴	2 ¹³	2 ¹²	2 ¹¹	2 ¹⁰	2 ⁹	2 ⁸	2 ⁷	2 ⁶	2 ⁵	2 ⁴	2 ³	2 ²	2 ¹	2 ⁰

$$V_{cc} = V_{cc}(\text{digital monitoring value}) \times \text{LSB}_{V_{cc}} = V_{cc}(\text{digital monitoring value}) \times 100\mu\text{V}$$

$$\text{TX Bias Current} = \text{TX Bias Current (Digital Value)} \times \text{LSB}_{\text{TX,Bias}} = \text{TX Bias Current (Digital Value)} \times 2\mu\text{A}$$

$$\text{TX Power} = \text{TX Power (Digital Value)} \times \text{LSB}_{\text{TXPower}} = \text{TX Power (Digital Value)} \times 0.1\mu\text{W}$$

$$\text{RX Power} = \text{RX Power (Digital Value)} \times \text{LSB}_{\text{RXPower}} = \text{RX Power (Digital Value)} \times 0.1\mu\text{W}$$

Digital Diagnostic Monitor Accuracy

Parameter	Typical Value	Note
Transceiver Temperature	± 3°C	
Power Supply Voltage	± 3%	
TX Bias Current	± 10%	
TX Optical Power	± 3dB	Note 1
RX Optical Power	± 3dB	Note 2

Notes:

- 1) Valid from -5 to 0 dBm.
- 2) Valid from -25 to 0 dBm.

Status Bits (2 Wire Address A2h)

Address	Bit	Name	Description
110	7	TX Disable State	Not implement.
110	6	Soft TX Disable	Not implement.
110	5	Reserved	
110	4	RX Rate Select State	Not implement.
110	3	Soft RX Rate Select	Not implement.
110	2	TX Fault	Digital state of the TX Fault Output Pin.
110	1	LOS	Digital state of the LOS Output Pin.
110	0	Data_Ready_Bar	

Alarm and Warning Flag Bits (2 Wire Address A2h)

Address	Bit	Name	Description
112	7	Temp High Alarm	Set when internal temperature exceeds high alarm level.
112	6	Temp Low Alarm	Set when internal temperature is below low alarm level.
112	5	Vcc High Alarm	Set when internal supply voltage exceeds high alarm level.
112	4	Vcc Low Alarm	Set when internal supply voltage is below low alarm level.
112	3	TX Bias High Alarm	Set when TX Bias current exceeds high alarm level.
112	2	TX Bias Low Alarm	Set when TX Bias current is below low alarm level.
112	1	TX Power High Alarm	Set when TX output power exceeds high alarm level.
112	0	TX Power Low Alarm	Set when TX output power is below low alarm level.
113	7	RX Power High Alarm	Set when Received Power exceeds high alarm level.
113	6	RX Power Low Alarm	Set when Received Power is below low alarm level.
113	5-0	Reserved Alarm	
114	All	Reserved	
115	All	Reserved	
116	7	Temp High Warning	Set when internal temperature exceeds high warning level.
116	6	Temp Low Warning	Set when internal temperature is below low warning level.
116	5	Vcc High Warning	Set when internal supply voltage exceeds high warning level.
116	4	Vcc Low Warning	Set when internal supply voltage is below low warning level.
116	3	TX Bias High Warning	Set when TX Bias current exceeds high warning level.
116	2	TX Bias Low Warning	Set when TX Bias current is below low warning level.
116	1	TX Power High Warning	Set when TX output power exceeds high warning level.
116	0	TX Power Low Warning	Set when TX output power is below low warning level.
117	7	RX Power High Warning	Set when Received Power exceeds high warning level.
117	6	RX Power Low Warning	Set when Received Power is below low warning level.
117	5-0	Reserved Warning	
118	All	Reserved	
119	All	Reserved	

Package Outline Drawing

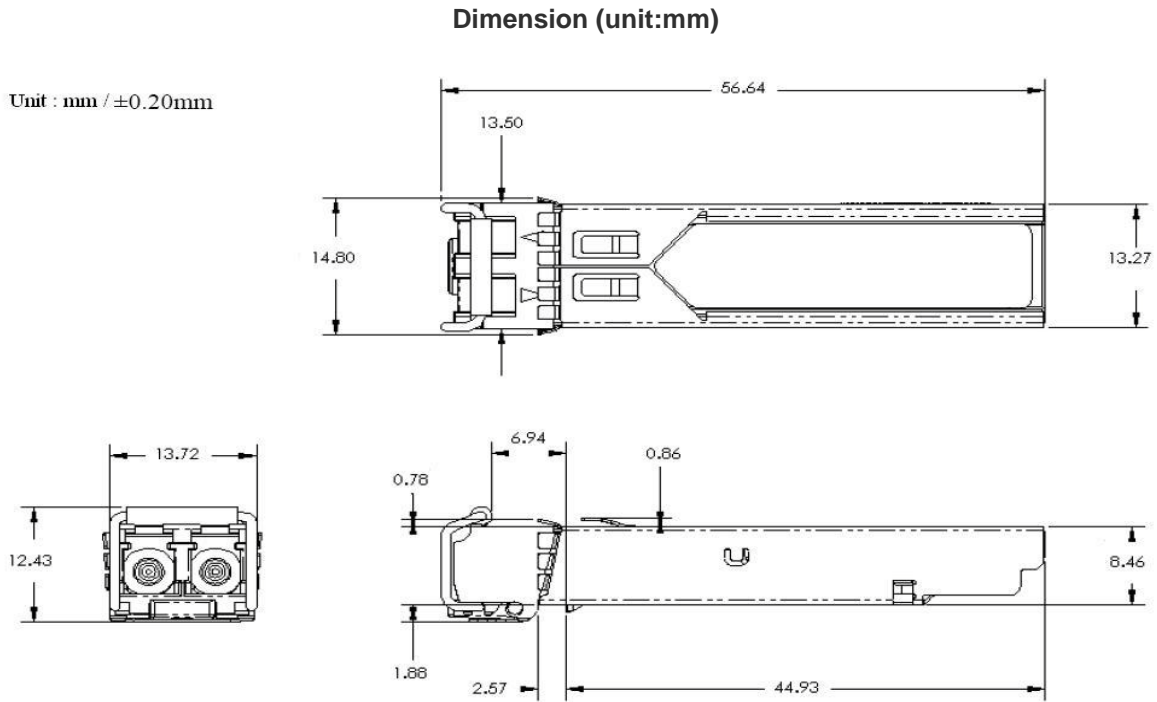

RoHS Reference

Material Classify	Substance	Reference	Standard	Analysis	Equipment
Heavy Metals	Lead (Pb)/ Lead Compounds	2002/95/EC	< 1000 ppm	US EPA 3050B	ICP-AES
	Cadmium (Cd)/ Cadmium Compounds	2002/95/EC	< 100 ppm	EN1122-2001 91/338/EEC	ICP-AES
	Mercury (Hg) / Mercury Compounds	2002/95/EC	< 1000 ppm	US EPA 3052	ICP-AES
	Hexavalent-Chromium(Cr6+)Compounds	2002/95/EC	< 1000 ppm	US EPA 3060A & 7196A	UV-VIS
Brominated Organic Compounds	PolyBrominated Biphenyls (PBB)	2002/95/EC	< 1000 ppm	US EPA 3540 & 3550	GC/MS
	PolyBromo Diphenyl Ethers(PBDE)	2002/95/EC	< 1000 ppm	US EPA 3540 & 3550	GC/MS

Qualification Information

Heading	Test	Conditions	Sample Size	Reference
Mechanical & Physical	Mechanical Shock	5 times/axis 500G , 1.0ms	11	MIL-STD-883 Method 2002
	Vibration	20G , 20Hz - 2000HZ 4min/cycle ,4cycles/axis	11	MIL-STD-883 Method 2007
	Thermal Shock	Delta T=100°C	11	MIL-STD-883 Method 2003
	Solderability	-	11	MIL-STD-883 Method 2007
	Fiber Pull	1Kg ; 3times ; 5sec	11	Bellcore 983
Endurance	Accelerated Aging	85°C , 5000hrs	25	Bellcore 983 Section 5.18
	High Temperature Storage	85°C , 2000hrs	11	Bellcore 983
	Low Temperature Storage	-40°C , 2000hrs	11	Bellcore 983
	Temperature Cycling	500 cycles.	11	Bellcore 983 Section 5.20
	Cyclic Moisture Resistance	10 cycles	11	Bellcore 983 Section 5.23
	Damp Heat	40°C , 95% RH , 1344hrs	11	MIL-STD-202 Method 103
Special Test	Internal Moisture	<5000ppm water vapor	11	MIL-STD-883 Method 1018
	Flammability	-	-	TR357 Sec.4.4.2.5
	ESD Threshold	-	6	Bellcore 983 Section 5.22