

120G CXP To 40G 3QSFP+ AOC 100m



Overview

CXP to 3xQSFP active optic cables are a high performance, low power consumption, long reach interconnect solution supporting 120G Ethernet, fiber channel and PCIe.

It is compliant with the 120Gbits Small Form factor Hot-Pluggable CXP-interface and QSFP-interface. APC CXP to 3xQSFP is an assembly of 12 full-duplex lanes, where each lane is capable of transmitting data at rates up to 10Gb/s, providing an aggregated rate of 120Gb/s.

Features

- ◆ QSFP+ End compliant to SFF-8436
- ◆ CXP End compliant to SFF-8642 and IBTA V2 Revision 1.2.1 Annex A6
- ◆ Full duplex 12CH 850nm parallel active optical cable
- ◆ Transmission data rate up to 10.3Gbit/s per channel
- ◆ Hot pluggable electrical interface
- ◆ Differential AC-coupled high speed data interface
- ◆ 12 channels 850nm VCSEL array
- ◆ 12 channels PIN photo detector array
- ◆ Up to 100m on OM3 MMF
- ◆ 3.3V power supply voltage
- ◆ Low power consumption: CXP End< 2W, QSFP End<1W
- ◆ Operating case temperature 0°C to +70°C
- ◆ RoHS 6 compliant

Applications

- ◆ InfiniBand 12xSDR, 12xDDR, 12xQDR
- ◆ Ethernet 10G, 40G, 100G
- ◆ Rack-to-Rack, Shelf-to-Shelf Interconnect
- ◆ Networking, NIC
- ◆ Storage: DAS, SAN, NAS
- ◆ Hubs, Switches, Routers, Servers

Ordering Information

Part Number	Product Description
ACX-120G-3Q-AOC-XX	120Gbps CXP to 40G 3QSFP+, Active Optical Cable, 100m on OM3 MMF, 0°C ~ +70°C
XX : 01~100,	1~100Length in meters on OM3 MMF

QSFP interface Specifications

Parameter	Description
Module Form Factor	QSFP+ (Supports SFF8436/SFF8472)
Channel Data Rate	Rate 40Gbps
BER	$<10^{-12}$
Operating Case Temperature	0 to + 70°C
Storage Temperature	-20 to + 85°C
Supply Voltage	3.3V nominal
Supply current	180mA per end typical
Management Interface Serial	I ² C (Supports SFF8472)

CXP interface Specifications

Parameter	Description
Module Form Factor	CXP (Supports SFF-8642)
Channel Data Rate	Rate 1 to 10.3125Gbps
BER	$<10^{-12}$
Operating Case Temperature	0 to + 70°C
Storage Temperature	-20 to + 85°C
Supply Voltage	3.3V nominal
Supply current	500mA maximum
Management Interface Serial	I ² C (Supports SFF8472)

Absolute Maximum Ratings

Parameter	Symbol	Min	Max	Unit
Supply Voltage	Vcc	-0.3	3.6	V
Input Voltage	Vin	-0.3	Vcc+0.3	V
Storage Temperature	Tst	-20	85	°C
Case Operating Temperature	Top	0	70	°C
Humidity(non-condensing)	Rh	5	95	%

Recommended Operating Conditions

Parameter	Symbol	Min	Typical	Max	Unit
Supply Voltage	Vcc	3.13	3.3	3.47	V
Operating Case temperature	Tca	0		70	°C
Data Rate Per Lane	fd	2.5		10.3	Gbps
Humidity	Rh	5		85	%

Fiber Bend Radius	Rb	3			cm
-------------------	----	---	--	--	----

Specifications

Parameter	Symbol	Min	Typical	Max	Unit
Differential input impedance	Zin	90	100	110	ohm
Differential Output impedance	Zout	90	100	110	ohm
Differential input voltage amplitude aAmplitude	ΔV_{in}	300		1100	mVp-p
Differential output voltage amplitude	ΔV_{out}	500		800	mVp-p
Skew	Sw			300	ps
Bit Error Rate	BR			E-12	
Input Logic Level High	V _{IH}	2.0		VCC	V
Input Logic Level Low	V _{IL}	0		0.8	V
Output Logic Level High	V _{OH}	VCC-0.5		VCC	V
Output Logic Level Low	V _{OL}	0		0.4	V

Note:

1. BER=10⁻¹²; PRBS 2³¹-1@10.3125Gbps.
2. Differential input voltage amplitude is measured between TxNp and TxNn.
3. Differential output voltage amplitude is measured between RxNp and RxNn.

Mechanical Dimensions

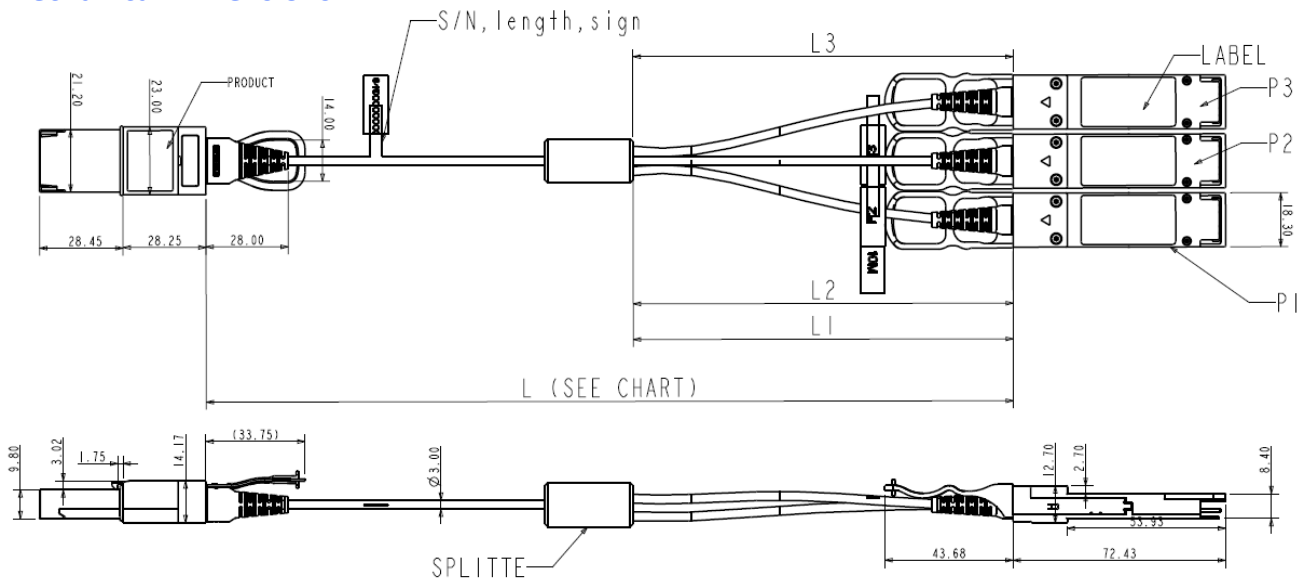

Figure1. Mechanical Specifications